

Our energy working for you.™



Power topic #9010 | Technical information from Cummins Power Generation

The Impact of Tier 4 Emission Regulations on the Power Generation Industry

White Paper

By Aniruddha Natekar, Sales Application Engineer
Matthew Menzel, Senior Application Engineer

In the U.S., diesel engine emissions have been regulated for almost forty years. For most of that time, the regulations governed primarily on-highway engines in trucks and buses, but in 1998 nonroad engines were also brought under the scope of the regulations. The Environmental Protection Agency (EPA) defined these nonroad engines as those used in mobile equipment such as farm tractors, construction earthmovers, mobile generator sets on trailers, and other portable industrial engines used in temporary off-road applications.

For a time, stationary engines were exempt from these new emission regulations. A stationary engine was defined as any engine that is permanently installed or located at a site for at least 12 months. This category included standby generator sets, on-site prime and distributed energy power systems, and a wide variety of industrial engines mounted on permanent bases or foundations. In the absence of federal standards, emissions from stationary diesel engines were usually governed by state and local permitting authorities.

But this situation changed with the EPA's issuance of the final New Source Performance Standards (NSPS) for compression-ignition (CI) engines in July 2006. When these standards went into effect on January 1, 2007, they harmonized regulations for most stationary diesel engine emissions with those for mobile nonroad emissions. Beginning January 1, 2011, these regulations will be divided based on application type: stationary emergency, stationary nonemergency, and nonroad mobile. Emergency stationary applications will only require new installations to comply with pre-2011 emissions limits. Any power duty rating (standby, prime, or continuous) may be applied to an EPA-defined "emergency stationary application" as long as it is used per the EPA's guidelines of an emergency situation or within the defined testing and maintenance run time requirements. The ISO rating of a generator set is not equivalent to the EPA's application type of the same unit.

Tiers of regulation

The first set of emission regulations, known as Tier 1, was published in 1996; ever since, the EPA has tightened these requirements, a trend that has encouraged technological advancements by engine manufacturers. With each successive tier of regulations, the permitted levels of nitrogen oxides (NOx) and particulate matter (PM), the two main pollutants from diesel engines, have gone down significantly. See Figure 1.

Evolution of EPA Off-Highway Emission Standards

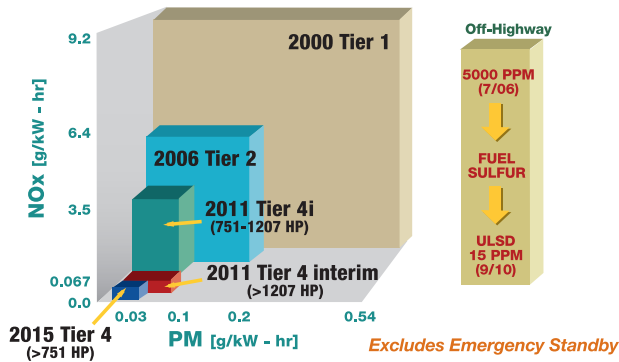

Figure 1.

Tier 4 levels represent more than a 95% reduction in tailpipe emission levels compared with nonregulated amounts. Also, note that fuel quality has improved over the years, dropping from 500 ppm of sulfur in low-sulfur diesel to a recent 15 ppm of sulfur in ultralow-sulfur diesel (ULSD).

It is worth noting that to accommodate existing inventory, the EPA allows two years from the date of a tier-level change to install an engine certified to comply with the previous tier. For example, generator sets with a prime mover rated between 603 and 751 HP are allowed to be installed after January 1, 2011 if being used in a stationary emergency application. However, these units may also be installed up until December 31, 2012 in nonemergency applications as long as the engine has a build date prior to January 1, 2011. Please see the emission schedule chart in Figure 2.

EPA CI NSPS for Stationary Engines Standards (60.4201, 60.4202, 60.4204, & 60.4205)

Requirements in **black** are same as nonroad; requirements in **red** are unique for stationary.

kW	(HP)	NOx-NMHC/CO/PM (g/kW-hr) [Conversion: (g/kW-hr) x 0.7457 = g/bhp-hr]									
		2007	2008	2009	2010	2011	2012	2013	2014	2015	2016
0 - 7	(0 - 10)	(7.5)/6.6/0.40									
8 - 18	(11 - 24)	(7.5)/5.5/0.30									
19 - 36	(25 - 48)	(7.5)/5.5/0.30							(4.7)/5.0/0.03		
37 - 55	(49 - 74)	Opt T4i: 0.30 PM: 37-55 kW Note 1									
56 - 74	(75 - 99)	(4.7)/5.0/0.40: 37-74 kW					3.4/0.19/5.0/0.02		0.40/0.19/5.0/0.02		
75 - 129	(100 - 173)	(4.0)/5.0/0.30									
130 - 224	(174 - 301)	(4.0)/3.5/0.20					2.0/0.19/3.5/0.02			0.40/0.19/3.5/0.02	
225 - 449	(302 - 602)	(4.0)/3.5/0.20					2.0/0.19/3.5/0.02			0.40/0.19/3.5/0.02	
450 - 560	(603 - 751)	(4.0)/3.5/0.20									
> 560	(> 751)	(6.4)/3.5/0.20					3.5/0.40/3.5/0.10		3.5/0.19/3.5/0.04		
		Stationary > 3000 hp: Tier 1					0.67/0.40/3.5/0.10 ^a		0.67/0.19/3.5/0.03 ^b		
		Tier 2		Tier 3		Tier 4 Interim		Tier 4 Final			

a. Applies to non-emergency power gen engines >900kW (>1207 hp)
 b. Applies to non-emergency power gen engines >560kW (>751 hp)

(1) Compliance with optional 'Option 1' 0.30 g/kW-hr PM limit in 2008 allows 1-year delay of T4 until 2013.
 Option 1 engines in 2008 are T4i engines, not T3 engines.
 (2) Fire pump requirements for 2007+ generally delayed three years.
 (3) Engines > 10 L/cyl must meet T2 marine requirements of 40 CFR 94.8.
 (4) There is NO TPEM program for engines in stationary applications.
 Rev 14 April 2009

Figure 2.

Schedule of implementation for tier levels.

Currently, engines producing less than 24 HP are required to comply with Tier 4 final emission regulations, and engines between 25 and 48 HP are required to comply with Tier 4 interim, or T4i.

Legacy equipment

Legacy equipment, certified to comply with the emissions standard in place for the year it was produced, can continue to be used in some regions with no restrictions. Legacy equipment can also be rebuilt and reused, provided it is rebuilt to the same or a newer emissions standard. Similarly, remanufactured engines can be used as replacements for retired legacy equipment, provided they meet the same or a newer emissions standard. On the other hand, remanufactured engines cannot be used to supplement a fleet unless they meet the latest emissions standard (currently Tier 4i), or there is a 1:1 retirement/replacement for engines predating Tier 4i emissions levels (Emissions Replacement Engine Policy).

In California, applicable legacy equipment may have to be registered with PERP (Portable Equipment Registration Program).



Our energy working for you.™
 www.cumminspower.com

©2010 Cummins Power Generation

Moving to Tier 4 interim and Tier 4 final

Currently, Tier 4 is the strictest EPA emissions requirement for off-highway diesel engines. For most of the power range, the final version of Tier 4 is phased in after an interim period (known as Tier 4i or T4i). Such interim requirements are less stringent on one of the main components of diesel exhaust emissions—either NOx or PM.

Since 2008, the Tier 4 requirement has been in effect for engines below 25 mechanical horsepower, while the Tier 4i requirement has been in effect for engines in the 25–48 HP range. For engines that are greater than 48 HP, Tier 4i is required in 2011 or 2012 depending on the power range, and Tier 4 final takes effect in 2013–2015, depending on the power range. Please note that these power ranges are based on the mechanical output of the engine and not the electrical output of the generator set.

Emergency power

The Tier 4 initial regulations govern most diesel engines used in power generation, industrial applications, oil and gas applications, mining operations, and mobile equipment. However, generators used in EPA-defined emergency stationary applications with an engine rating at greater than 49 HP are exempt from this new standard and are allowed to stay at 2010 emissions tier levels when the regulations change in 2011 (for engines of 174 HP and greater) or 2012 (for engines of 49 HP–173 HP). These generators provide power only in the event of a disruption of the normal power source. Generators used for peak shaving or as the normal source of power, on the other hand, need to comply with the Tier 4 interim or Tier 4 final emissions limits because they do not operate solely when utility power is lost. The specific verbiage from the EPA defining what constitutes an emergency situation can be found in the 40 CFR 60 Subpart IIII Section 4219:

“Emergency stationary internal combustion engine means any stationary internal combustion engine whose operation is limited to emergency situations and required testing and maintenance. Examples include stationary ICE used to produce power for critical networks or equipment (including power supplied to portions of a facility) when electric power from the local utility (or the normal power source, if the facility runs on its own power production) is interrupted, or stationary ICE used to pump water in the case of fire or flood, etc. Stationary CI ICE used to supply power to an electric grid or that supply power as part of a financial arrangement with another entity are not considered to be emergency engines.”

It should be noted that the duty rating of a generator (standby, prime, or continuous) does not correlate to the EPA's emissions certification requirement; the application type itself is the determining factor. The purpose of the duty rating is to indicate the generator's capability as defined by ISO 8528. Any power duty rating may be applied to an EPA-defined “emergency stationary application” as long as it is only used per the EPA's guidelines of an emergency situation or within the defined testing and maintenance run time requirements. The most common example of an application classified as emergency stationary would include gensets used to produce power for critical networks or equipment when electric power from the normal power source is interrupted. A prime or continuous power rated genset may be used in this application and be EPA compliant at the previous Tier level if the application only requires the unit to run in an emergency stationary capacity. Alternatively, the most common examples of applications which will not fall under the emergency stationary guidelines would be utility peak shaving operations and gensets being used to provide normal power to a facility. Under the EPA's guidelines, these would be classified as stationary nonemergency and would need to meet Tier 4i emissions limits.

Emission regulation in nonattainment areas

The EPA sets National Ambient Air Quality Standards (NAAQS) for several pollutants, including NOx and PM. For those areas of the country that exceed NAAQS levels, which are referred to as nonattainment areas, the EPA requires that states come up with plans that identify needed actions to improve air quality in those areas. While EPA-designated nonattainment areas represent a fraction of the land area of the country, they are typically heavily populated areas.

Thus, certain states and localities might impose additional emissions standards for diesel-powered generator sets, primarily for NOx and PM. Generator set applications in these nonattainment areas may be required to comply with the most stringent emissions regulations, which could necessitate the use of the Best Available Control Technology (BACT). These BACT measures generally include aftertreatment devices like selective catalytic reduction (SCR) and particulate traps for reduction in emission levels.

California regulations

The California Air Resource Board's (CARB's) Air Toxic Control Measure (ATCM) may also require emission levels stricter than the EPA requirements. The ATCM may necessitate the use of aftertreatment devices such as a diesel oxidation catalyst (DOC), a diesel particulate filter (DPF) or a selective catalytic reduction (SCR) unit. It is always advisable to check to see what local regulations are applicable to the installation site, either through the local regulator of air quality or your local provider of power generation equipment.

Certified vs. verified solutions

The method to prove compliance with a local regulatory authority could also be different from what is required by the EPA. While the EPA requires that the engine manufacturer prove compliance through a certification process, the local authority requiring compliance with an emissions level more stringent than the EPA's may require only a site certification or a verification process. It is advisable to work with your local regulator or your power generation equipment provider to better understand what is required to prove compliance.

Solving the emissions seesaw

PM and NOx, two significant constituents of diesel engine emissions, have often been considered as two sides of a seesaw. On the one hand, high temperatures and excess oxygen are conducive to the formation of NOx. So lowering the in-cylinder temperatures and oxygen content reduces NOx; however, it also increases the production of soot (PM), thanks to lower fuel conversion efficiency. Decreasing both these constituents at the same time has challenged engine manufacturers to develop innovative and alternative solutions.

In-cylinder solutions

All existing technologies to meet the Tier 4 emission levels can be classified as either in-cylinder or aftertreatment approaches.

In-cylinder technology can include:

1. New combustion bowl geometry for optimum combustion.
2. Multiple fuel injection capabilities that provide more combustion control and better part load performance in terms of emissions and fuel consumption, without sacrificing power.
3. Advanced fuel injection systems, such as modular common rail fuel injection, that provide improved stability, cold start and transient response, while maintaining power densities.
4. Solenoid-controlled electronic injectors, which add precision to the delivery of fuel.
5. New engine control modules with improved sensors that control engine operating parameters more precisely and are critical to maximizing power output.
6. High-durability ferrous cast ductile (FCD) pistons, which are stronger than aluminum, especially when operating at higher temperatures. They help deliver optimal power output.
7. Charge air cooling to reduce the temperature of the turbocharged air before it enters the combustion chamber.
8. Cooled exhaust gas recirculation (EGR), which recycles a part of the exhaust to lower combustion chamber temperatures and to reduce emissions at part loads. Intercooling further aids in lowering in-cylinder temperatures.



Our energy working for you.™
www.cumminspower.com

©2010 Cummins Power Generation

9. Variable geometry turbocharger, which gives precise control of airflow at all engine speeds and loads, and which provides the necessary pressure differential to drive EGR.
10. "Miller Cycle" engine design using variable valve actuation (VVA), which allows for late intake valve closing, thereby reducing the effective compression ratio and resulting in lower compression temperatures and therefore lower NOx.

Aftertreatment technologies

Such in-cylinder techniques can only do so much, however, because of the mechanical limits of current engines. A close look at the EPA's emission schedule also reveals that as the engine power increases, the allowed emission levels actually are reduced. This calls for something beyond in-cylinder technological advancements. Welcome to the world of aftertreatment.

Here there are also multiple strategies that can be used. Depending on the requirement, some or all of the following can be used:

1. DOC, or a diesel oxidation catalyst, a flow-through device where exhaust gases are brought in contact with materials that oxidize unburned hydrocarbons and reduce emissions.
2. DPF, or diesel particulate filter, a device designed to physically capture particulate matter from the exhaust stream.
3. SCR, or selective catalytic reduction unit, which includes a "reducer" that is added to exhaust flow to create the reactions in a catalytic chamber.

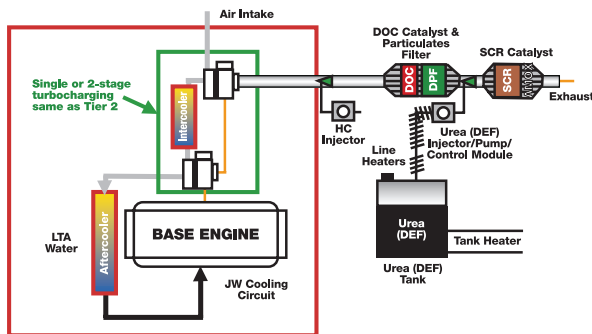

Figure 3.
A combination of available aftertreatment technologies.

Concerns with aftertreatment technology

Other than the obvious downside of additional costs, aftertreatments come with some concerns that need to be carefully addressed. Cooling the exhaust gas before recirculating it, for example, is an effective method for reducing in-cylinder temperatures, but the cooling system then has to deal with an additional cooling circuit and up to 25% higher heat rejections.

In addition, aftertreatment solutions can raise concerns about packaging and space limitations, as well as about thermal management and substance-level constraints like the handling and storage of urea, a material used in SCR technologies, as well as sulfur tolerance. (Diesel fuel with lower amounts of sulfur is less stable than higher-sulfur diesel fuel and more susceptible to microorganisms growing in the fuel tank.)

In addition, some aftertreatment devices can add a significant amount of backpressure, requiring precise, duty-cycle-based control of temperatures and dosing frequency for regeneration. Such devices also represent an additional item to be serviced. Finally, most NOx aftertreatment devices reduce emissions when operating at high temperatures, but such temperatures may not even be reached by an emergency standby generator that is lightly loaded.



Figure 4.
SCR units (insulated in gray) can take up a considerable amount of space.



About the authors

Aniruddha Natekar started with Cummins Power Generation in 2007. As a sales application engineer, he provides technical recommendations on installations and engineering support to customers, assists the sales force with technical training, and supports technical seminars.

Aniruddha has an M.S. in automotive engineering from Lawrence Technological University (Southfield, Michigan) and a B.S. in mechanical engineering from the University of Pune (India). He held positions in R&D, market research, engineering and product development with a number of automotive companies prior to joining Cummins Power Generation.



Matthew Menzel is a graduate of the University of Minnesota with a bachelor of mechanical engineering. He has been with Cummins Power Generation since 2008 as an application engineer. Matthew's primary focus is on assisting clients

and distributors with technical guidance on application-specific issues concerning standard commercial products and unique projects. He is also actively engaged in the Power Seminar program as well as providing technical training content to support distribution teams in the North American market.

Transition Program for Equipment Manufacturers

The EPA created the Transition Program for Equipment Manufacturers, or TPEM, to provide original equipment manufacturers (OEMs) with flexibility to comply with the new emission regulations. This program allows equipment manufacturers to produce a specific percentage or number of units with engines meeting the previous tier standards. The program is only available for nonroad (mobile) applications; stationary applications cannot make use of this program. If your particular application falls under the nonroad category, contact your power generation equipment provider to better understand if you can purchase equipment under this program.

Conclusion

Spurred by the EPA's Tier 4 emission regulations, the industry has developed cleaner and greener energy solutions. Tier 4 mandates a significant reduction in both NOx and PM levels, which may require complex emission abatement strategies on the engines. It is important to understand if your particular application requires a generator set that meets or exceeds Tier 4 regulations. Work with your power generation equipment supplier to acquire the right generator set for your application.

For additional technical support, please contact your local Cummins Power Generation distributor. To locate your distributor, visit www.cumminspower.com.



Our energy working for you.™
www.cumminspower.com

©2010 Cummins Power Generation Inc.
All rights reserved. Cummins Power Generation and Cummins are registered trademarks of Cummins Inc. "Our energy working for you.™" is a trademark of Cummins Power Generation.
PT-9010 (11/10)